

## **Class HMS-AC FLUX VECTOR Movable Bridge Drives**

### **Three-Phase Adjustable Speed**

### **Standard Features**



Fincor Class HMS-AC *Flux Vector* drive systems provide smooth, stepless, adjustable speed controls for Movable Bridge Drives. The units feature high efficiency, electronic conversion of AC line power source for precise control of motor speed and torque over a wide range of operating speeds and loading. The HMS-AC units are derived from Fincor general purpose, industrial drives by the addition of required features for operation of Movable Bridge Systems.

A. Basic Controller 208-230 or 460V, 3 Phase 50/60 Hz, 0-40 deg. C, 1.0 S.F., 3,300 Ft. El.

1. NEMA 12 ventilated optional

2. HMS-AC with the following features:

*(NOTE: Adjustments are made via PLC link or the keypad)*

#### **ADJUSTMENTS**

a. Acceleration/Deceleration	.01 - 3200 seconds (Typ.) linear or S-ramp Independently adjustable.
b. Torque Limit	0-200% of rated
c. Minimum Speed (Freq.)	0-100%
d. Maximum Speed (Freq.)	0-100%
e. Frequency Regulation	.001Hz (Typical )

---

**MAIN A.C. SYSTEM DISCONNECT W/ HANDLE**

**POWER CONVERSION** – Open loop (V/F), Roto-Flux Control, or Close Loop Flux Vector modulation.

**DUAL MICROPROCESSOR DESIGN** – Powerful 32-bit based

**SERIAL COMMUNICATIONS** – 2 or 4-wire RS 232 or RS 485

**ISOLATED REGULATOR** - Internal circuits are isolated from the AC power source for operator and equipment safety.

**POWER LOSS RIDE-THROUGH** – Maintains motor control during periods of input power loss for a minimum of 1 second.

**MOTOR OVERLOAD PROTECTION** – Electronically protects motor from overheating due to loading conditions

**UNDERVOLTAGE and OVERVOLTAGE PROTECTION** - Electronic shutdown when the line voltage exceeds +/- 10% of rated input.

**OPERATORS PANEL** - Units include a versatile, digital control panel mounted in the front cover of the unit. The panel includes a membrane keypad, and a smart LCD display that enables its use for setup monitoring of all controller functions and operating parameters, self diagnostic purposes, and also as a local operator control station. The operator panel is a smooth, unbroken surface which is easy to keep clean and is sealed to prevent the penetration of liquids or dust.

***Display*** - LCD display provides operating and function setup. Display is back lighted, enabling viewing in extremes of lighting conditions including total darkness. Displays motor speed, motor load and power, and indicates all programmable functions and faults in English language word messages.

***Visual Indicators*** - LED's are provided to indicate power on, direction, run/jog, stop and operating mode.

***Keypad Memory*** - Nonvolatile

**LINE – TO – LINE and LINE – TO - GROUND PROTECTION**

**50/60 HZ OPERATION**

---

**RUGGED MODULAR CONSTRUCTION**

3. CONTROL TRANSFORMER – Conservable rated control transformer
4. MOTOR OUTPUT CONTACTOR - Magnetic contactor provides a positive disconnection of the motor from the controller power source anytime the unit is in a stop mode.
5. RFI / EMI / LINE CHOKES / ISOLATION TRANSFORMERS, Three phase AC line reactors or isolation transformer on the primary side of the inverter are available.

**B. Added Requirements for Movable Bridge Controls**

1. *Drive Related*

a. **Speed Feedback Loss Protection and Comparator:**

In order to reliably compare input (speed setting) to output frequency (motor speed) a internal logic fault detector is incorporated. The actual output frequency is monitored at all times. A contact is included in the stop circuit and a signal light is incorporated to indicate a fault due to a difference in voltage level between the input (speed setting device) and the output frequency.

b. **Motor Overheat Protection:**

Normally closed motor thermal switch terminals are provided as standard in the drive which will initiate a Normal Stop if the motor overheats.

2. *Movable Bridge Related*

a. **Overspeed Protection:**

The speed of the AC motor is controlled by the frequency output of the Inverter. If the frequency reference fails, the inverter will shut down immediately thus stopping the drive.

b. **Proof of Torque (Mechanical Brake interface contact)**

A N.O. aux. contact is supplied to insure that the motor is energized and torque is being developed before the mechanical brake is released.

3. *Relay Logic Related*

a. **Normal Stop:**

A stop initiated by a stop push button, or thermal guard will initiate a "normal" stop which is a controlled linear ramp deceleration to approximately 20-50 RPM of the main drive motor at which time the motor (prime mover) is both electrically and mechanically disconnected from the power source and the mechanical brake (if provided) is applied.

b. **Emergency Shutdown:**

A stop initiated by an emergency shutdown push button or an internal inverter fault will initiate a "Emergency Shutdown" which will immediately disconnect the motor mechanically and electrically from the power source.

## C. General Requirements

### 1. **Main AC Motor (Prime Mover) - 230 or 460/3/60:** *(APPLICATION DEPENDANT)*

Foot Mounting or C-face

RPM depending on system requirements

1.0 Service Factor

TEFC, TENV or TEBV Construction available

Class B Insulation

High Efficiency Inverter Duty Motor

Motor mounted encoder

Separately powered blower *(when required)*

## D. Options Available for Drive

### 1. **Isolation Transformers** - See Specification 7300

### 2. **Line Chokes**

### 3. **RFI/EMI Filter**

### 4. **Drive**

Larger enclosures to house additional custom logic as required

- b. Line Regenerative capability
- c. Enclosure heating (strip heaters)
- d. Enclosure lighting
- e. Enclosure receptacle
- f. Speed Indicator (Door Mounted Analog or Digital)
- g. AC load meter on drive enclosure
- h. Serial Interface capability (software and cable)
- i. Fincor HMI/PLC interface system

**BASIC BLOCK DIAGRAM**

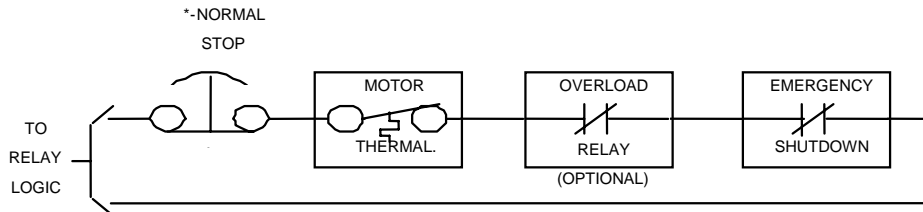
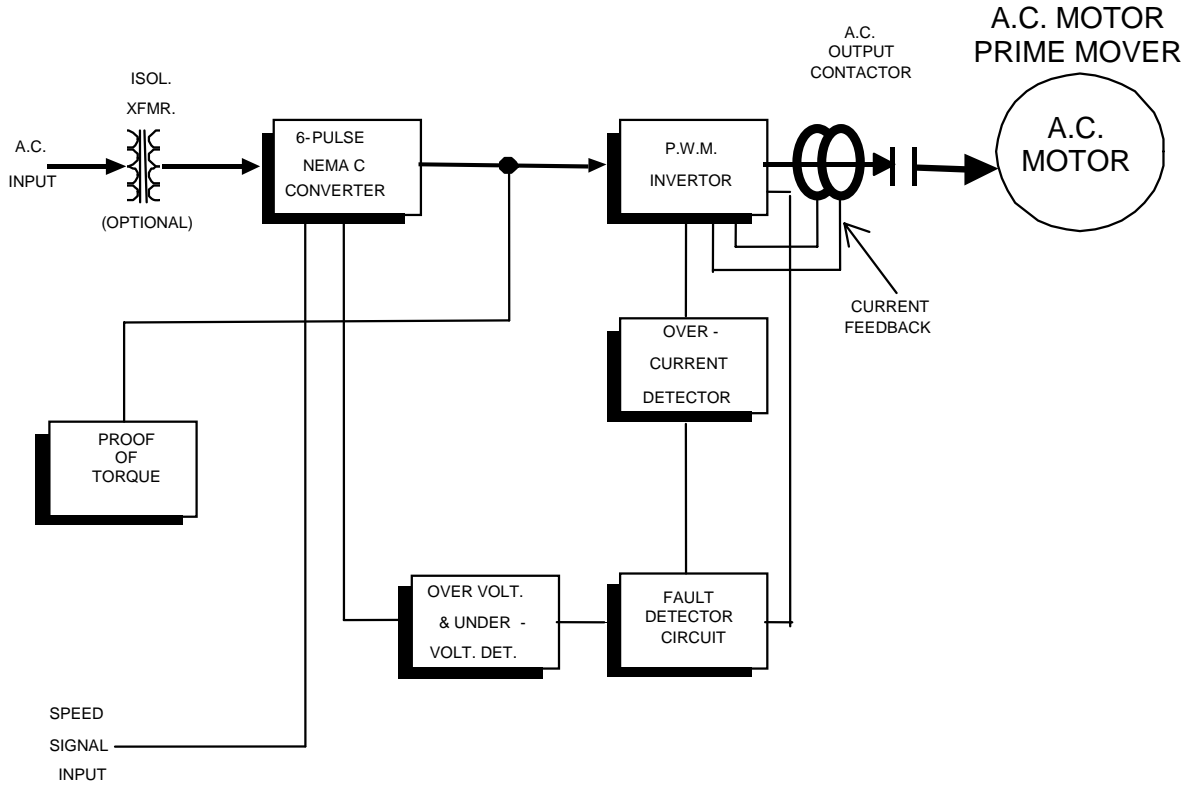

**NORMAL STOP CIRCUIT**

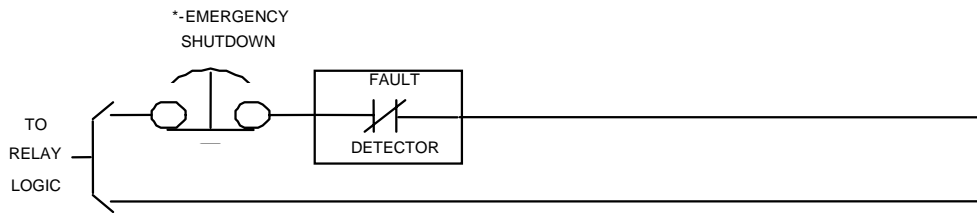

**EMERGENCY SHUTDOWN CIRCUIT**

\*- ADDITIONAL BUTTONS CAN BE PROVIDED AS AN OPTION